

ADSL CPE SIDE SPLITTER
P/N: AD-2039C DATA SHEET



Bothhand USA. e-mail: sales@bothhandusa.com http://www.bothhand.com

Feature



- The ADSL low pass filter is used to block any Noise generated by other phones, fox's being Introduced on the POTS line.
- Typically 2nd an 3rd order filters are Used to gain the selection of the cancellation of the voice band harmonics.
- Data and voice connection links operate independently And preventing mutual interface between those signals.
- Operating Temperature: -10°C to+60.°C
- Storage Temperature: -25°C to +75°C.
- Operation Humidity 10 To 90 % RH.

Electrical Speciofications @ 25°C

Parameter	Condition	Min.	Typ.	Max.	Units
Impedance	300to3.4KHz		600		ohm
Insertion loss	1004Hz short loop			-1.0	dB
	1004Hz long loop			-0.75	dB
Attenuation Distortion	200 to 3.4KHz	-1.5		1.5	dB
	3.4K to4.0 KHz	-2.0		2.0	dB
	200to3.4KHz	-1.5		0.5	dB
	3.4Kto4.0KHz	-1.5		1.0	dB
Cut off frequency	12KHz		-3.0		dB
Attenuation	30-300KHz	-4.5			dB
	300K-1140KHz	-5.5			dB
Delay Distortion	600to1.2KHz			200	us
	200to4KHz			250	us
Return Loss	ERL	-6			dB
	SRL-L	-5			dB
	SRL-H	-3			dB
Longitudinal Balance	200 to 1KHz	-58			dB
	1 to 4KHz	-53			dB
DC Resistance				20	Ω
DC Current				100	mA

ADSL CPE SIDE SPLITTER
P/N: AD-2039C DATA SHEET



Bothhand USA. e-mail: sales@bothhandusa.com http://www.bothhand.com

Schematic

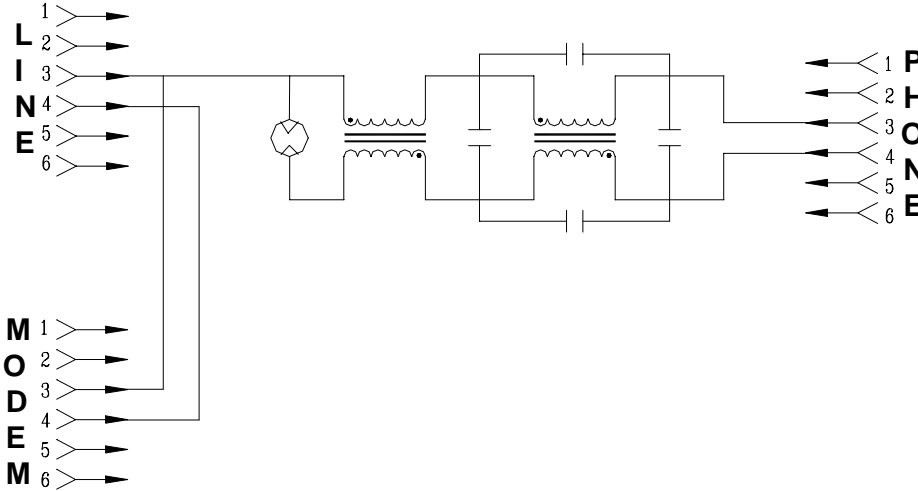

Mechanical

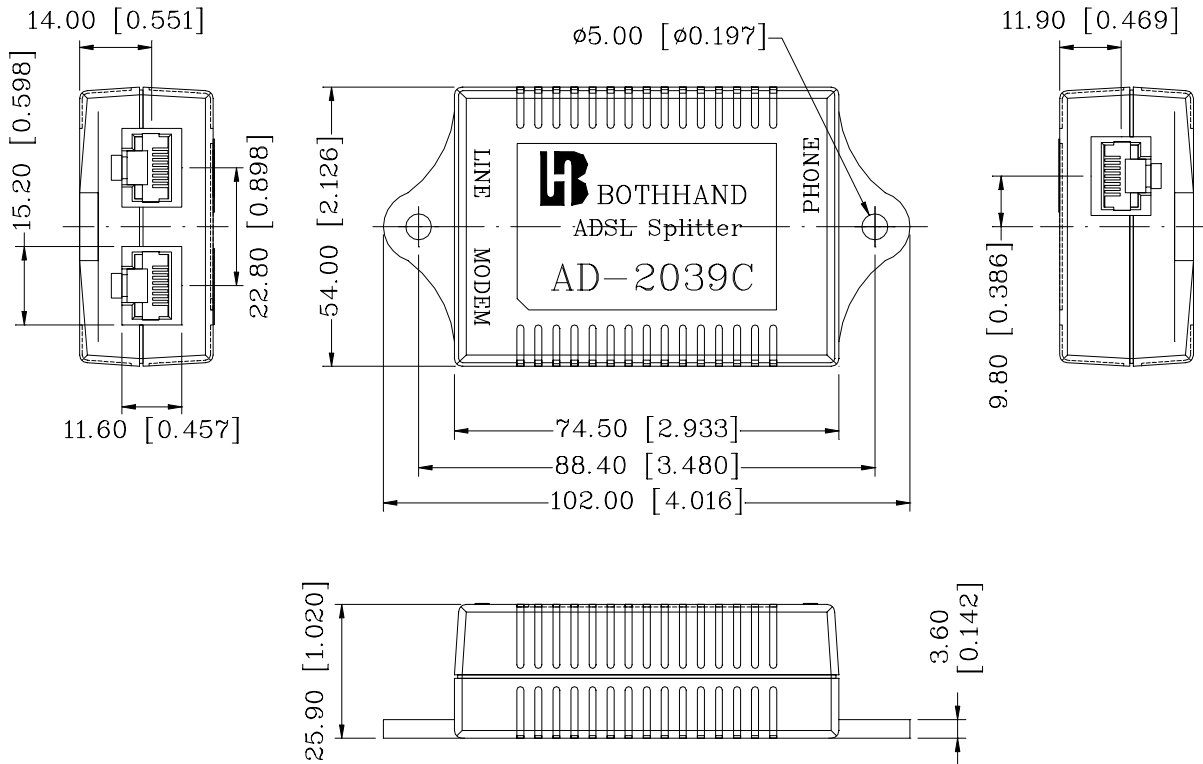

Units: mm[Inches] Tolerances: xx.x0±0.25[0.010]
 0.xx±0.05[0.002]

Component

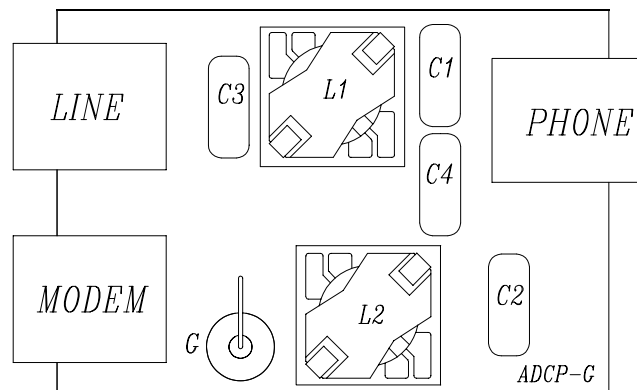

Up-Side Component
Top View

Insertion loss

For each of the test loops specified in above and using the test set-up shown in Figure 1 the insertion loss from the source to the termination shall be measured with and without the splitter/ZH-r combination inserted.

The increase in insertion loss at 1004HZ on any of the test loops , due to the addition of the Splitter/ZH-r shall be less than specified in Electrical Specification table.

The insertion loss of a device connected into a given transmission system is defined as the ratio, expressed in dB , of the load power available(before and after insertion) delivered to the output network beyond the point of insertion at a given frequency. In general , the insertion loss of a device inserted in a given transmission system mainly caused by internal component resistive loss while all of the impedance between source , load and deice interface having been matched. TO perform the insertion loss measurement ,thru calibration must be done prior the testing.

General Insertion loss equation can be expressed as following

Insertion loss = $20 \log | V2 / V1 |$ dB where

V1=the measured voltage value of without LPF in circuit

V2=the measured voltage value of with LPF in circuit

The test setup is shown in drawing below:

Figure 1

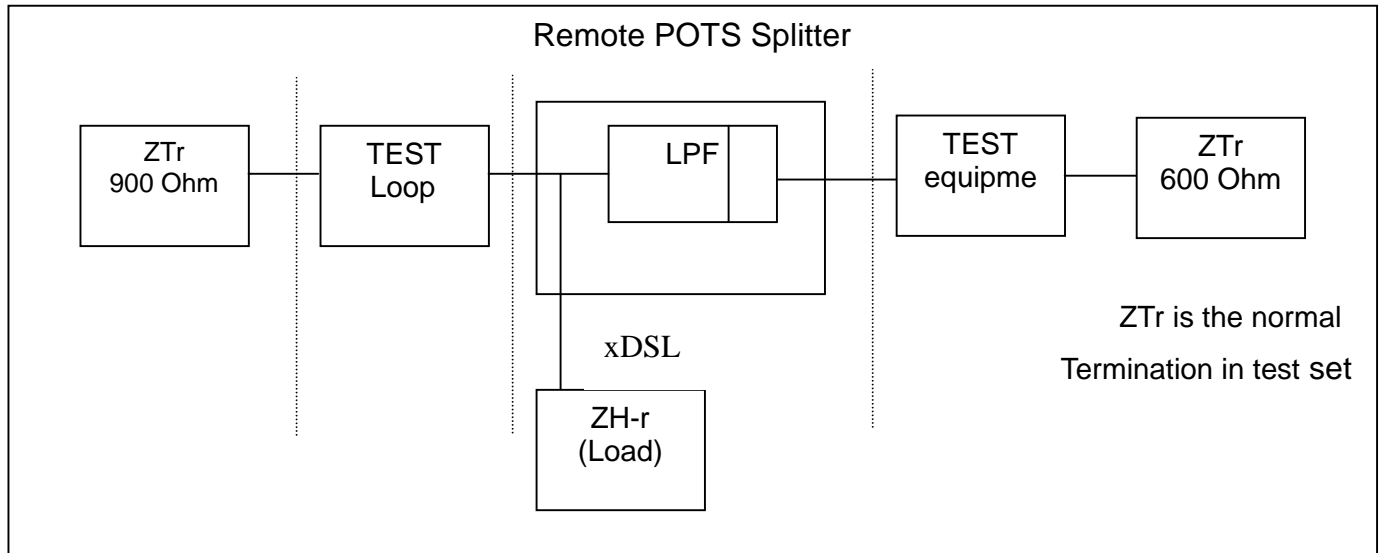

Note : ZH-r is the impedance presented to the POTS connection by an TAU-R

Return loss:

The Return Loss is measure of the driving point impedance variation introduced by the filter, variation of the driving point impedance of the loop can affect POTS performance by changing the sidetone balance of a telephone instrument or the front end hybrid balance of voiceband modern.

This test measure three specific frequency weighted return loss value each return loss(ERL)low-band singing return loss(SRL-L), and high-band singing return loss(SRL-H). For detailed description of the weighting functions see IEEE743-1985.

Return loss measure the amount of energy that is lost due to reflection which resulted from impedance mismatching at the interface. Return loss is essentially defined as the ratio of the power incident upon a given transmission system to the power reflected caused by impedance mismatch with respect to reference impedance at the interface between source and device.

Return loss figure are a function of the impedance of the circuit involved and are therefore frequency dependent.

These impedance must be closely maintained in order to reduce the possibility of

ADSL CPE SIDE SPLITTER
P/N: AD-2039C DATA SHEET



Bothhand USA. e-mail: sales@bothhandusa.com http://www.bothhand.com

undesirable reflection and echoes which in long distance circuit the telephone user or destroy the data being sent To perform the return loss test ,open ,short, load calibration must be done prior measurement while the LCZ impedance Analyzer being selected in impedance mode. Return loss is general expressed in decibels. General Return loss equation as below.

$$\text{Return loss} = 20 \log \left| \frac{Z_{NLr} + Z_m}{Z_{NLr} - Z_m} \right| \text{ dB}$$

Where ZNL = the reference impedance Zm= the measured impedance

The test setup is shown in drawing below:

Figure 2

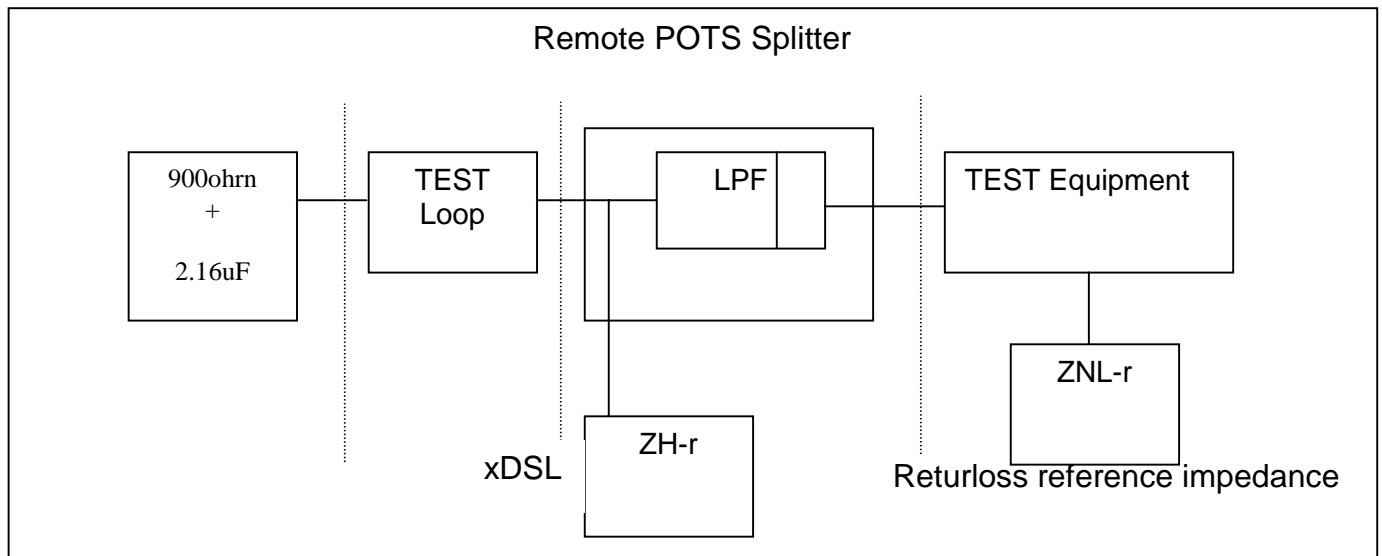

- 1:ZNL-r=1330 ohm in parallel with series connection of a 348ohrn resistor and a 100nF capacitor (long loop model seen from RT).
- 2:ZH-r is the impedance presented to the POTS connection by an ATU-R.